

HSR-007

High Speed Rolling Aluminum Doors

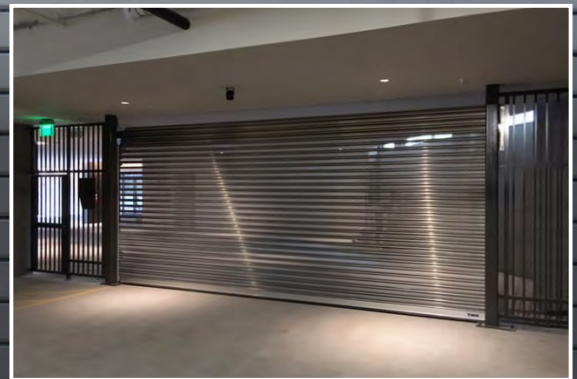

TNR® offers high performance rolling doors that provide:

HIGH SPEED & SECURITY

SUPERIOR AESTHETICS

ENERGY-SAVING INSULATION



***Tough 'n' Ready
For Your Challenging
Environments***

TNR

HSR-007 HIGH SPEED ALUMINUM DOORS

The High Speed Rolling Aluminum door models are a great solution for buildings needing a door with high speed operation, security, energy-saving insulation and superior aesthetics. Condominium parking, automobile dealerships and private parking entrances are well served by this high performance, reliable rolling door.

TNR® Mechanical Features

- The HSR-007 high speed rolling door models are easy to install and maintain. Available as an insulated slat or perforated slat curtain.
- The premium aluminum double wall insulated slat has a high density polyurethane foam core that provides thermal insulation and a durable composite structure.
- The single wall perforated aluminum slat offers a lower cost secure door that provides ventilation to the enclosed space.
- Galvanized steel guides with rigid UHMW wear strips, combined with end locks and storm hooks ensure smooth and secure door operation.
- Sleek door profile with reduced clearances allows for easy retrofit installation.
- Guide-mounted thru-beam photoelectric sensor, wireless reversing edge, emergency stop on panel, manual chain hoist.
- Door Sizes (W x H): 8' x 8' up to 19' x 19'
- Interior or Exterior mount. Optional hoods.

TNR® Drive Features

- Heavy Duty Gear Direct Drive operator
 - integrated safety brake
 - variable frequency drive
 - soft start / soft stop
- Springless design
- Control Options: Plug and Play, loop detector, motion detector, remote radio controls.

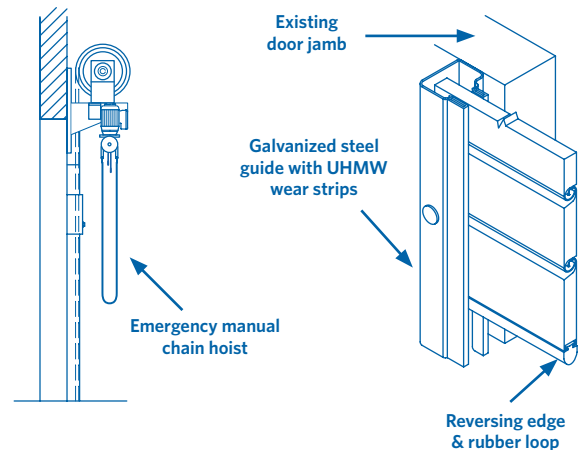
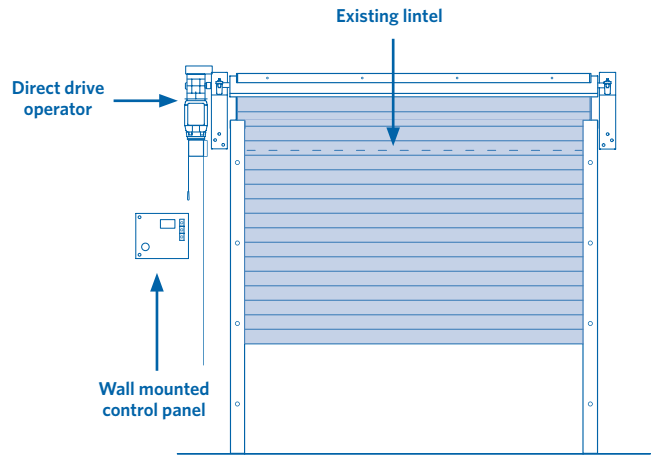

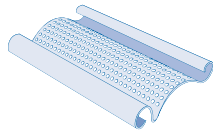
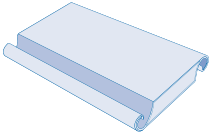
Model	HSR-007A Slat	HSR-007B Slat
Description	Single Wall, Perforated	Double Wall, Insulated
Exterior	Aluminum, mill finish	Aluminum, Anodized Grey
Interior	Aluminum, mill finish	Foil Coated, Grey White (RAL9002)
Thickness, total	0.05 inch	0.875 inch
Slat	Perforated for 26% air flow, 0.155" diameter holes	Rigid Polyurethane Foam Insulation, R-value 6.1
Up/Down Door Speeds (up to)	18/12 inches per second	54/30 inches per second
Window Size	N/A	3.125" Wide 2.125" High
Window Material	N/A	polycarbonate
Profile		

Warranty—Five years or 1,000,000 cycles on operator. One year on all curtain components. Two years on all other parts and workmanship.

Toll-free 1-866-792-9968 Fax 1-705-735-9564 info@tnrdoors.com TNRdoors.com

