

Product Specification Sheet

Model MO-OPH Jackshaft Operator

Dyna-Hoist®



Standard Features

- **Motor:**

60Hz high starting torque, continuous-duty, single phase capacitor start or 3 phase motor, open drip proof, protected against overload.

- **Reduction:**

First step in reduction 5L/B V-belt drive, additional steps by chain and sprockets. Input shaft is 5/8", supported by precision ball bearings. Output shaft is 1" with 1/4" keyway, supported by ball bearings. Output shaft speed: 41 rpm.

- **Clutch:**

Friction type, positioned on input shaft, easily adjustable from outside.

- **Drive:**

#50 roller chain with a 50B12 sprocket for the operator drive shaft. Door sprocket selected for a door travel of 6"/s to 12"/s.

- **Brake:**

Mechanical brake.

- **Manual Operation:**

Hoist-a-matic® self-engaging hoist (floor level engagement device is not required to operate) for manual chain operation. An electrical interlock automatically disconnects power to the motor operator when the chain hoist is engaged. Hoist on right is standard.

- **Electrical Enclosure:**

All electrical components are in a Nema 1 enclosure. Hinged electrical enclosure cover.

- **Limit System:**

Rotary-type oil-impregnated steel cams, commercial grade switches. Limit shaft is supported by self-lubricating bronze bushings for increased precision. Remains in time when there is a manual operation or after the motor has been removed.

- **Accu-cam® Feature:**

Precise and quick one-handed adjustment of the limits.

- **Corrosion Protection:**

Frame and control enclosure protected by baked on, long lasting enamel finish. All shafts protected by yellow chromate coating.

- **Mounting:**

Wall, hood, or shelf mounted on the right or on the left of the door. For indoor use only.

- **Shipping Weight:**

Approx. 86 lbs - 39 kg.

- **Warranty:**

2 Years.

⁽¹⁾ For properly balanced rolling steel doors with less than 80 lbs of imbalance, rolling sheet doors, vinyl doors or equivalents. For larger rolling doors, we recommend using an electrically activated drum-band type solenoid brake, see Mechanical Modifications.

Hoist-a-matic®

Self-engaging chain hoist with automatic cut-off

Accu-cam® Limit Feature

For precise and quick one-hand limit setting adjustments

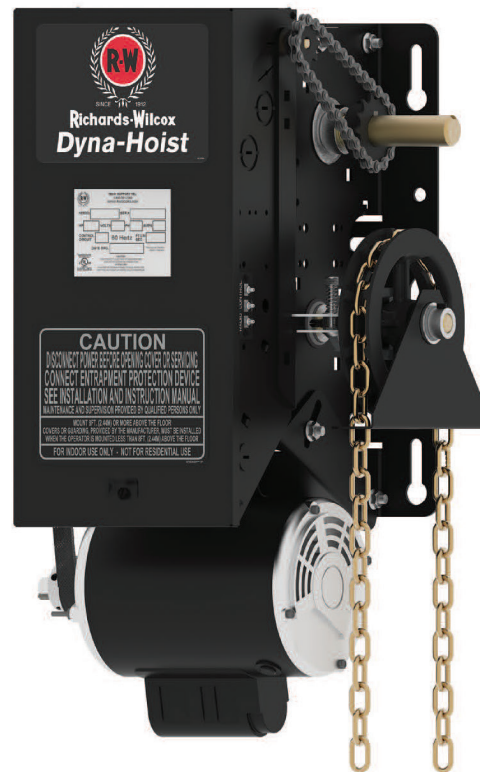

The MO-OPH model is a heavy-duty industrial operator designed for use on standard, high and vertical lift sectional doors or rolling doors⁽¹⁾ and grilles.

The operator can be wall, hood, or shelf mounted on either side of the door. It incorporates the patented Hoist-a-matic®, a self-engaging chain hoist for manual operation, which simplifies operation and installation.

The operator is available with the Electronic Control Board (BOARD 070) with or without the option of electrical control for monitored external entrapment protection devices (UL325-2010 compliant).

Control Options

• ECB Units (BOARD 070):

24Vdc relaying circuit with a 40VA class II transformer, non-volatile memory. Features available: On-board radio receiver, 1.5s delay on reverse, programmable maximum run timer, mid-stop, timer to close (suspension possible from floor level), independent input loop terminal, advance close system, test buttons, reverse wiring detection and door lock sensor.

Operating mode selectable on site: C2, B2, D1, E2, T or TS.

• "M" Version:



Provides the monitoring of Primary External Entrapment Protection Devices. Includes monitored photo cells (PHOTO 070 standard). In this mode, Ancillary Entrapment Protection Devices (optional) may be used to supplement primary entrapment protection, such as non-monitored photo cells, 2-wire non-monitored sensing edges and pneumatic sensing edges. Certifications: CSA C22.2-247.92 and UL325.

• "E" Version:



No monitoring function.

Certifications: CSA C22.2-247.92 and compliant to UL325 5th Ed. PRIOR to August 2010 revision.

Note: CSA C22.2-247.92 and UL325 apply to units intended to be used in ordinary locations in accordance with the Canadian Electrical Code, Part I and the National Electrical Code, NFPA 70, respectively.

Main Options

• Control Accessories:

Angled terminal strip allows for the connection of 3-button stations (one supplied with the operator), non-monitored sensing edges, non-monitored photo cells, one push-button radio control (external strip), ceiling pull switches, key switches, loop detectors, external interlocks, universal auxiliary output module. 2A fuse protected 24Vac output is available for accessory power supply. NEMA 4/12 or NEMA 4X protected monitored photo cells upgrade available.

• Mechanical Accessories:

Wall or hood mounting bracket, chain spreader, etc...consult inside sales.

• Mechanical Modifications:

Left hand chain hoist, electrically activated drum-band type solenoid brake, cast iron flanged pillow block bearings on output shaft, limit shaft speed-up, etc...consult inside sales.

Dimensions

Clearance: Side room required 15" (380 mm)

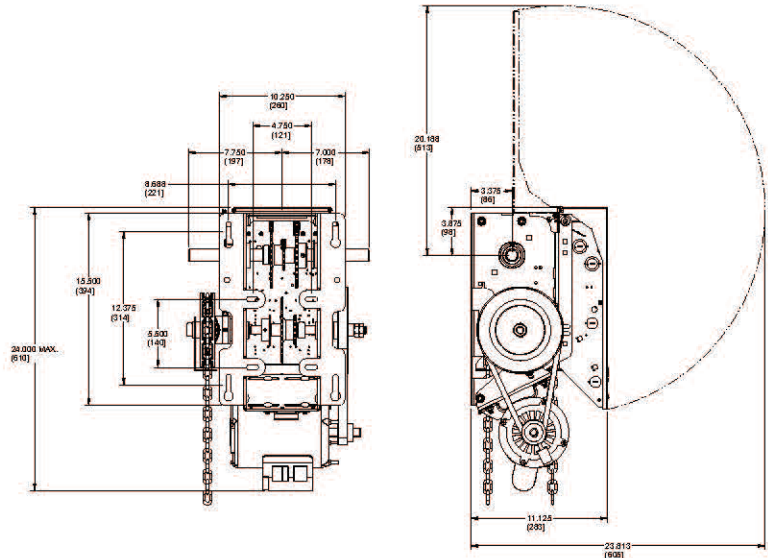

Operator Range and Pricing (Ex: MO-OPH-6112-0E00)

Code	Circuit Type	HP	Volts	Ph	Amp
MO-OPH-6112-0	E	1/2	120	1	8.0
MO-OPH-6212-0	E	1/2	240	1	4.0
MO-OPH-6232-0	E	1/2	208	3	2.1
MO-OPH-6432-0	E	1/2	480	3	1.0
MO-OPH-6532-0	E	1/2	600	3	0.8
MO-OPH-6113-0	E	3/4	120	1	11.2
MO-OPH-6213-0	E	3/4	240	1	5.6
MO-OPH-6233-0	E	3/4	208	3	3.2
MO-OPH-6433-0	E	3/4	480	3	1.5
MO-OPH-6533-0	E	3/4	600	3	1.2
MO-OPH-6114-0	E	1	120	1	13.6
MO-OPH-6214-0	E	1	240	1	6.8
MO-OPH-6234-0	E	1	208	3	4.4
MO-OPH-6434-0	E	1	480	3	2.1
MO-OPH-6534-0	E	1	600	3	1.6

Door sprocket up to 50B23 (1-1/4" Bore, 1/4" Keyway)
Other sprocket combinations
Hand chain for door shaft >14'

Options

Code	Description
(M) Version	Monit.+N1 M-Photo Cells
SPREADER001	Spreader for 1" / 1"
SPREADER002	Spreader for 1" / 1-1/4"
RADIOEM101	1-button transmitter
RADIOEM103	3-button transmitter

Accu-Cam / Hoist-a-matic are Registered T.M. of Manarac-Opera
Dyna-Hoist is a Registered T.M. of Raynor Canada Corp.